

L-SERIES
COMPACT LOADERS



JOHN DEERE

204L / 304L



**LOW PROFILE,
HIGH ABILITY**

THE
L-SERIES



+



VERSATILE PRODUCTIVE



GO-GETTERS.



MAKE SHORT WORK OF YOUR NEXT TASK.

Our 204L and 304L Compact Loaders combine serious performance with low clearance, so you can be more productive even when navigating low entryways and narrow openings. Choose an open canopy for quick and easy entrance/exit. Or opt for an air-conditioned/heated cab for year-round comfort and ability. Standard skid-steer-style quick-coupler and auxiliary hydraulics, plus numerous compatible Worksite Pro™ attachments, further add to their do-it-all flexibility.

CAN DO

GIVE IT YOUR ALL WITH THESE MASTER MULTITASKERS.

Boasting serious breakout forces and solid full-turn tipping-load capacities, the 204L and 304L get it done. And with a top speed of 12 mph, and up to 3-ft. 1-in. reach and 8-ft. 7-in. dump clearance, they're an attractive alternative to skid steers for loading trucks or placing pallets on trailers.

Smooth operator

Elastic articulation at the pivot point smooths the ride for greater load retention and reduced operator fatigue.

Stable platform

Low center of gravity and exceptional balance add up to impressive stability and full-turn tipping-load capacities. Precise parallel control over the entire lift range helps ease material handling.

Carry more, spill less

Limited-slip differential lock automatically delivers the power to the tire with the best traction for extra bucket-filling effort. Optional ride control also helps keep buckets full and forks loaded.

Excellent visibility

Tapered lift arms and single boom and bucket cylinders enhance visibility without sacrificing breakout force.

Generous FT4 power

Smooth-running EPA Final Tier 4 (FT4) diesels meet rigid emission standards and pack plenty of power and torque reserve.



TOP SPEED OF
12 MPH



STAR PERFORMERS THAT KEEP A LOW PROFILE

NEVER COME UP SHORT.

Whether you use them for shuttling seed, heaping hoppers, loading landscape materials, or whatever — these low-profile compacts navigate with ease through low entryways and narrow openings. And because not every operation needs all the bells and whistles, you can equip yours with a no-frills, purpose-built open canopy.



8-FT. HEIGHT
TO TOP OF CAB



Go low

Just 8-ft. tall, our L-Series Compacts deliver lower clearance than many wheel loaders in their class — and are nearly a full foot lower than our 244K-II.

Comfortable four-season cabs

For year-round comfort, equip your machine with an optional heated and air-conditioned low-profile cab. Expansive curved tinted glass and narrow corner posts enable excellent visibility.

Lockable covers

Optional lockable monitor and switch covers provide after-hours security and vandal protection.

Touch and go

Boom, bucket, F-N-R, and now 3rd-function hydraulic controls are positioned on the same ergonomic low-effort lever, for convenient one-hand control. Fingertip control of the coupler, travel speed, park brake, lights, and other machine functions are also close and within easy reach.

Purpose-built canopies

ROPS-certified open-canopy models are perfect for applications requiring the operator to frequently get on and off the machine. Unlike the canopies on other loaders that are little more than cabs with the glass removed, ours are designed to withstand the elements — with weather-resistant gauges, extended rooftops, nonskid floor mats, and optional vandal proofing.

WORKING OUR CONNECTIONS

HELPS YOU WORK YOURS

Looking to build your business? Worksite Pro attachments are a great place to start. With more than 100 models, they'll help you broaden your abilities, work smarter, and accomplish even more.



Skid-steer-style coupler

Push-button-actuated skid-steer-style coupler lets an operator attach and release attachments quickly from the seat. What's more, the coupler doesn't require special adapters that curtail bucket breakout or rollback.

Creep control

Optional creep control allows slow incremental travel speeds while maintaining full hydraulic flow. It's ideal for hydraulic-driven attachments such as brooms.

Make a clean sweep

Pickup brooms let you sweep up dust and debris, and haul it away or deposit it in a dumpster.

Snow business

Blades, buckets, and pushers make these loaders naturals for removing whatever winter drops your way.

Grab and go

Brush, scrap, and utility grapples employ two hydraulic-actuated dual-action tongs for superior retention of a wide variety of materials.

Add these to your bucket list

For moving mulch, shuttling sand, or carving through clay, we've got the right bucket for the job. Capacities range from 1.0 to 2.1 cu. yd.

Farmhands

These loaders are right at home on the farm. Equip one with a bale spear, forks, or a bucket to handle a multitude of chores.



100+
MODELS
OF WORKSITE PRO
ATTACHMENTS

***DO
MORE.***

LOW OVERHEAD

IN MORE WAYS THAN ONE.

Low-profile machines that keep costs down, too

With L-Series Loaders, low overhead also applies to maintenance. We provide extended service intervals for engine oil/filter, final drive oil, and hydraulic oil.

Simple to service

Easy-access vertical filters and environmental drains make fluid changes quick and clean. Convenient maintenance and lube chart helps confirm that nothing gets overlooked.

We've got your back

Should parts or service be required, they're readily available at more than 1,400 John Deere dealer locations from coast to coast.



Quick, ground-level service

Lockable easy-open tilting hoods provide convenient, ground-level access to daily checkpoints, as well as periodic service items such as fluids and filters. Ground-level fuel fill and see-through coolant reservoir also help simplify daily maintenance.

Reliable cooling

Cooler cores are easily accessible for quick cleanout. Engine-mounted belt-driven cooling fan delivers efficient, reliable performance.

JDLink™ machine monitoring

Optional JDLink provides machine data and health alerts to help you decrease costly downtime.





204L SPECIFICATIONS

Engine		204L
Manufacturer and Model	Yanmar 4TNV98	
Non-Road Emission Standard	EPA Final Tier 4 (FT4)	
Cylinders	4	
Valves per Cylinder	4	
Displacement	3.3 L (203 cu. in.)	
Net Peak Power at 2,200 rpm (ISO 9249 and SAE J1349)	45 kW (61 hp)	
Gross Rated Power at 2,200 rpm (ISO 14396)	48 kW (63 hp)	
Peak Torque at 1,200 rpm (ISO 9249 and SAE J1349)	239 Nm (176 lb.-ft.)	
Engine Bore and Stroke	98 x 110 mm (3.89 x 4.33 in.)	
Lubrication	Pressure system with full-flow spin-on filter	
Fuel System	High-pressure common rail	
Aspiration	Naturally aspirated	
Air Cleaner	Dual safety element dry type	
Cooling		
Fan	Direct driven	
Engine Coolant Rating	-37 deg. C (-34 deg. F)	
Powertrain		
Type	Hydrostatic (HST) with infinitely variable speed control over full range of operating speeds; 2 speed ranges; joystick-mounted F-N-R; acceleration pedal; HST inching pedal, which allows infinitely reduced travel speeds while maintaining full engine rpm and hydraulic flow	
2 Travel Speeds in Forward and Reverse (equipped with 365/70R18 tires)		
Gear 1	6.0 km/h (3.7 mph)	
Gear 2	20.0 km/h (12.0 mph)	
Axles	Rigid-mount front and rear axles with 10-deg. frame oscillation	
Rear Axle Oscillation Versus Front Axle	20 deg. total, stop to stop	
Differentials	45% locking front and rear differentials	
Maximum Rise and Fall, Single Wheel	254 mm (10 in.)	
Steering	Hydraulic power steering (SAE J1511); 40-deg. articulation left and right	
Steering Wheel Turns, Stop to Stop	3.5 left to 4.5 right	
Articulation Angle	80-deg. arc (40 deg. each direction)	
Final Drive	Heavy-duty outboard planetary	
Brakes (SAE J1473 and ISO 3450)		
Service Brakes	Hydraulically actuated, self-adjusting internal wet-disc brake and driveline drum brake	
Parking Brake	Automatically spring-applied, hydraulically released, internal wet disc	
Hydraulics		
Main Pump (loader and steering)	Fixed-displacement gear pump; open-center system	
Maximum Rated Flow at 6895 kPa (1,000 psi) and 2,200 rpm	70 L/m (18 gpm)	
System Relief Pressure		
Loader	23 000 kPa (3,335 psi)	
Steering	18 002 kPa (2,611 psi)	
Hydraulic Cycle Time		
Raise	5.6 sec.	
Dump	1.5 sec.	
Lower (float down)	4.7 sec.	
Lower (power down)	4.3 sec.	
Total	11.4 sec.	
Controls	3-function valve with single-lever control for boom and bucket, with hydraulic lockout feature; joystick-mounted push-button electrohydraulic (EH) control for auxiliary hydraulics, with hydraulic lockout feature; ride control electrically actuated for improved ride quality (factory and field option)	
Cylinders		
Type	Heat-treated, chrome-plated, polished cylinder rods; hardened steel (replaceable bushings) pivot pins	

204L SPECIFICATIONS



Electrical		204L	
Type	Electrical load center with blade-type multi-fused circuits		
Voltage	12 volt		
Number of Batteries	1		
Battery Capacity	850 CCA		
Reserve Capacity	80 min.		
Alternator Rating	80 amp		
Lights (SAE 99)	Driving/front working lights (2), rear working lights (2), turn signals, flashers, and stop- and taillights		
Operator's Station			
Noise Level			
Operator Ear	78 dba		
Bystander	101 dba		
Tires/Wheels			
Tires on Single-Piece Rims	<i>Tread Width*</i>	<i>Width Over Tires†</i>	<i>Change in Vertical Height</i>
365/70R18 Mitas EM-01 (standard)	1397 mm (4 ft. 7 in.)	1760 mm (5 ft. 9 in.)	—
400/70R20 Michelin XMCL (optional)	1376 mm (4 ft. 6 in.)	1790 mm (5 ft. 10 in.)	+30 mm (+1.2 in.)
405/70R18 Firestone Duraforce (optional)	1427 mm (4 ft. 8 in.)	1790 mm (5 ft. 10 in.)	+9 mm (+0.3 in.)
*Also see Q in Dimensions section on pages 14 and 16. / †Also see R in Dimensions section on pages 14 and 16.			
Serviceability			
Refill Capacities			
Cooling System (engine and radiator)	12.0 L (12.7 qt.)		
Differential and Planetary Axle			
Front	6.0 L (6.4 qt.)		
Rear	6.0 L (6.4 qt.)		
Engine Oil with Filter	10.0 L (10.8 qt.)		
Fuel Tank	50.0 L (13.2 gal.)		
Hydraulic/HST Reservoir with Filter	90.0 L (23.8 gal.)		
HST Motor Gearbox	1.0 L (1.1 qt.)		
Operating Weights			
With standard equipment, 365/70R18 tires, standard counterweight, 79-kg (175 lb.) operator, and full fuel tank			
	<i>With Enclosed Cab</i>	<i>With Canopy ROPS</i>	
Quik-Tatch™ Quick-Coupler			
With 0.8-m ³ (1.0 cu. yd.) Stockpiling/General-Purpose Bucket with Bolt-On Edge	5355 kg (11,806 lb.)	5235 kg (11,541 lb.)	
With 1.1-m ³ (1.4 cu. yd.) Stockpiling/General-Purpose Bucket with Bolt-On Edge	5465 kg (12,048 lb.)	5345 kg (11,784 lb.)	
With Fork	5282 kg (11,645 lb.)	5162 kg (11,380 lb.)	
ISO Quick-Coupler			
With 0.8-m ³ (1.0 cu. yd.) Stockpiling/General-Purpose Bucket with Bolt-On Edge	5150 kg (11,354 lb.)	5030 kg (11,089 lb.)	
With 1.1-m ³ (1.4 cu. yd.) Stockpiling/General-Purpose Bucket with Bolt-On Edge	5249 kg (11,572 lb.)	5129 kg (11,307 lb.)	
With Fork	5050 kg (11,133 lb.)	4930 kg (10,869 lb.)	
Optional Components			
Quik-Tatch Quick-Coupler			
With 0.8-m ³ (1.0 cu. yd.) Stockpiling/General-Purpose Bucket with Bolt-On Edge	535 kg (1,179 lb.)	535 kg (1,179 lb.)	
With 1.1-m ³ (1.4 cu. yd.) Stockpiling/General-Purpose Bucket with Bolt-On Edge	645 kg (1,421 lb.)	645 kg (1,421 lb.)	
With Fork Frame and Forks (Class 3B)	336 kg (741 lb.)	336 kg (741 lb.)	
ISO Quick-Coupler			
With 0.8-m ³ (1.0 cu. yd.) Stockpiling/General-Purpose Bucket with Bolt-On Edge	330 kg (728 lb.)	330 kg (728 lb.)	
With 1.1-m ³ (1.4 cu. yd.) Stockpiling/General-Purpose Bucket with Bolt-On Edge	429 kg (946 lb.)	429 kg (946 lb.)	
With Fork Frame and Forks (Class 2)	240 kg (529 lb.)	240 kg (529 lb.)	

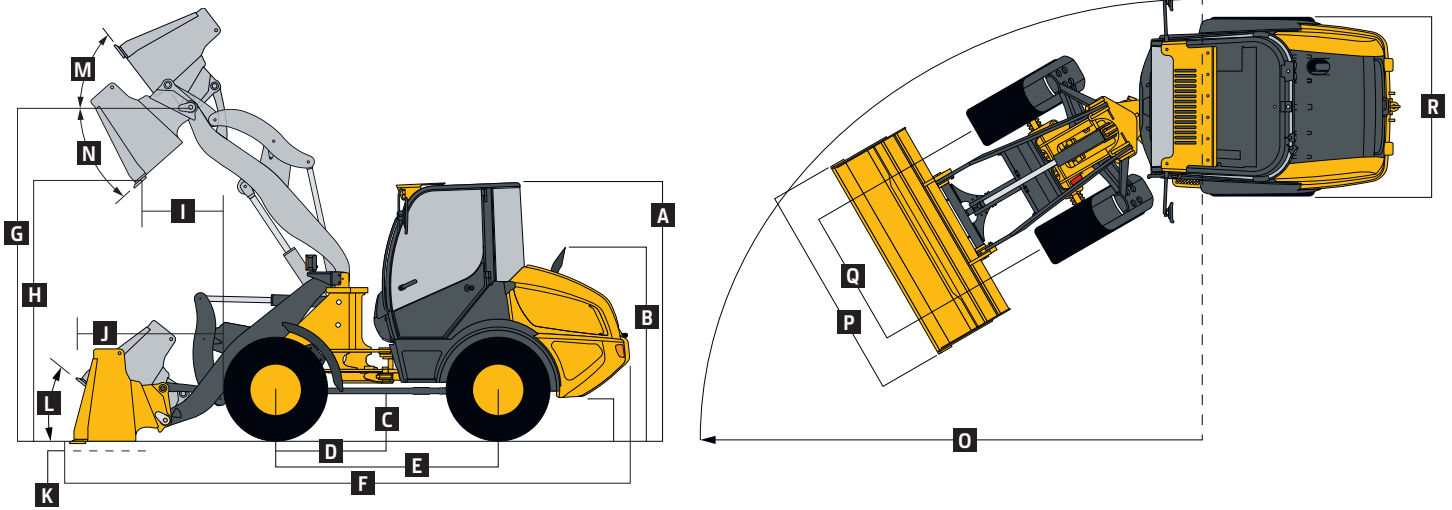

204L LOADER WITH QUIK-TATCH COUPLER AND BUCKET

Dimensions with Quik-Tatch Coupler and Bucket	<i>0.8-m³ (1.0 cu. yd.) stockpiling/ general purpose with bolt-on edge</i>	<i>1.1-m³ (1.4 cu. yd.) stockpiling/ general purpose with bolt-on edge</i>
A Height to Top of Cab	2.45 m (7 ft. 11 in.)	2.45 m (7 ft. 11 in.)
B Height to Top of Exhaust	1.80 m (5 ft. 11 in.)	1.80 m (5 ft. 11 in.)
C Ground Clearance	318 mm (12.5 in.)	318 mm (12.5 in.)
D Length from Centerline to Front Axle	1067 mm (3 ft. 6 in.)	1067 mm (3 ft. 6 in.)
E Wheelbase	2.15 m (7 ft. 1 in.)	2.15 m (7 ft. 1 in.)
F Overall Length, Bucket on Ground	5.42 m (17 ft. 10 in.)	5.46 m (17 ft. 11 in.)
G Height to Hinge Pin, Fully Raised	3.18 m (10 ft. 5 in.)	3.18 m (10 ft. 5 in.)
H Dump Clearance, 40-deg. Full Height	2.43 m (8 ft. 0 in.)	2.38 m (7 ft. 9 in.)
I Reach, 40-deg. Dump, Full Height	920 mm (3 ft. 0 in.)	968 mm (3 ft. 2 in.)
J Reach, 42-deg. Dump, 2.13-m (7 ft.) Clearance	1.49 m (4 ft. 11 in.)	1.54 m (3 ft. 11 in.)
K Maximum Digging Depth	70 mm (2.8 in.)	70 mm (2.8 in.)
L Maximum Rollback at Ground Level	37 deg.	37 deg.
M Maximum Rollback, Boom Fully Raised	65 deg.	65 deg.
N Maximum Bucket Dump Angle, Fully Raised	40 deg.	40 deg.
O Turning Circle Radius Over Outside of Bucket Edge	4.23 m (13 ft. 11 in.)	4.29 m (14 ft. 1 in.)
P Bucket Width	1.90 m (6 ft. 3 in.)	2.20 m (7 ft. 3 in.)
Q Tread Width (standard) ⁶	1397 mm (4 ft. 7 in.)	1397 mm (4 ft. 7 in.)
R Width Over Tires (standard) ⁶	1760 mm (5 ft. 9 in.)	1760 mm (5 ft. 9 in.)
⁶ Also see <i>Tires/Wheels</i> section on page 13.		
Specifications with Quik-Tatch Coupler and Bucket		
Capacity, Heaped	0.8 m ³ (1.0 cu. yd.)	1.1 m ³ (1.4 cu. yd.)
Capacity, Struck	0.66 m ³ (0.86 cu. yd.)	0.90 m ³ (1.18 cu. yd.)
Breakout Force	4170 kg (9,190 lb.)	3770 kg (8,311 lb.)
Tipping Load, Straight	3700 kg (8,157 lb.)	3550 kg (7,826 lb.)
Tipping Load, 40-deg. Full Turn	3280 kg (7,231 lb.)	3130 kg (6,900 lb.)
Rated Operating Load, 50% of Full-Turn Tipping Load (conforms to ISO 14397-1)*	1640 kg (3,616 lb.)	1565 kg (3,450 lb.)

*Rated operating capacity based on Deere attachments only.

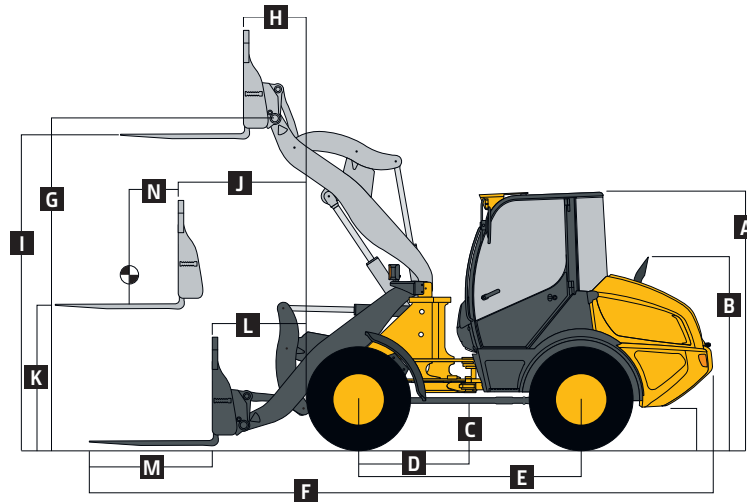

204L LOADER WITH QUIK-TATCH COUPLER AND FORK

Dimensions with Quik-Tatch Coupler and Fork	<i>1.22-m (48 in.) tine length</i>
A Height to Top of Cab	2.45 m (7 ft. 11 in.)
B Height to Top of Exhaust	1.80 m (5 ft. 11 in.)
C Ground Clearance	318 mm (12.5 in.)
D Length from Centerline to Front Axle	1067 mm (3 ft. 6 in.)
E Wheelbase	2.15 m (7 ft. 1 in.)
F Overall Length, Forks on Ground	5.92 m (19 ft. 5 in.)
G Height to Hinge Pin, Fully Raised	3.18 m (10 ft. 5 in.)
H Reach, Fully Raised	450 mm (18 in.)
I Fork Height, Fully Raised	3.00 m (9 ft. 10 in.)
J Maximum Reach, Fork Level	1.22 m (4 ft. 0 in.)
K Fork Height, Maximum Reach	1.37 m (4 ft. 6 in.)
L Reach, Ground Level	780 mm (31 in.)
M Tine Length	1.22 m (48 in.)
N Load Position, 50% Tine Length	0.61 m (24 in.)
Specifications with Quik-Tatch Coupler and Fork	<i>As measured with fork level, centered on tine</i>
Tipping Load, Straight	2930 kg (6,460 lb.)
Tipping Load, 40-deg. Full Turn	2580 kg (5,688 lb.)
Rated Operating Load, 50% Full-Turn Tipping Load (conforms to ISO 14397-1 and SAE J1197)*	1290 kg (2,844 lb.) [†]
Rated Operating Load, Rough Terrain, 60% Full-Turn Tipping Load (conforms to EN474-3)*	1550 kg (3,417 lb.) [†]
Rated Operating Load, Firm and Level Ground, 80% Full-Turn Tipping Load (conforms to EN474-3)*	1720 kg (3,792 lb.) [†]

*Rated operating capacity based on Deere attachments only.

[†]Payload on forks is limited by tilt cylinder.

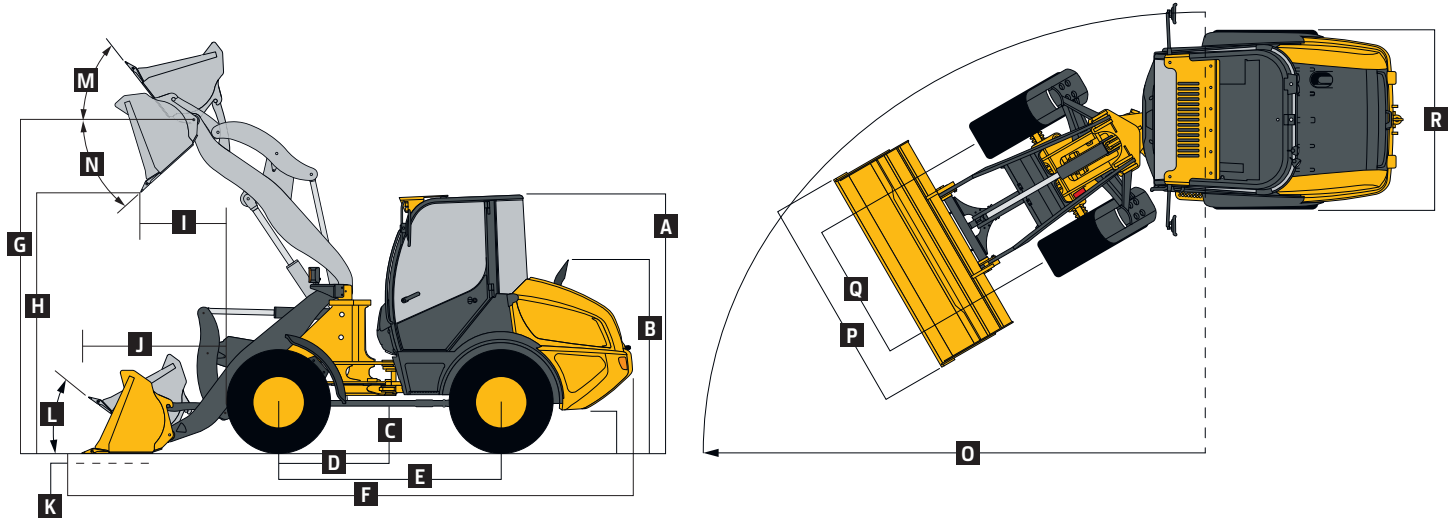

204L LOADER WITH ISO PARALLEL-PIN "EURO" COUPLER AND BUCKET

Dimensions with ISO Parallel-Pin "Euro" Coupler and Bucket	0.8-m ³ (1.0 cu. yd.) hook-on stockpiling/general purpose with bolt-on edge	1.1-m ³ (1.4 cu. yd.) hook-on stockpiling/general purpose with bolt-on edge
A Height to Top of Cab	2.45 m (7 ft. 11 in.)	2.45 m (7 ft. 11 in.)
B Height to Top of Exhaust	1.80 m (5 ft. 11 in.)	1.80 m (5 ft. 11 in.)
C Ground Clearance	318 mm (12.5 in.)	318 mm (12.5 in.)
D Length from Centerline to Front Axle	1067 mm (3 ft. 6 in.)	1067 mm (3 ft. 6 in.)
E Wheelbase	2.15 m (7 ft. 1 in.)	2.15 m (7 ft. 1 in.)
F Overall Length, Bucket on Ground	5.42 m (17 ft. 10 in.)	5.46 m (17 ft. 11 in.)
G Height to Hinge Pin, Fully Raised	3.18 m (10 ft. 5 in.)	3.18 m (10 ft. 5 in.)
H Dump Clearance, 40-deg. Full Height	2.43 m (8 ft. 0 in.)	2.38 m (7 ft. 9 in.)
I Reach, 40-deg. Dump, Full Height	920 mm (3 ft. 0 in.)	968 mm (3 ft. 2 in.)
J Reach, 42-deg. Dump, 2.13-m (7 ft.) Clearance	1.49 m (4 ft. 11 in.)	1.54 m (3 ft. 11 in.)
K Maximum Digging Depth	70 mm (2.8 in.)	70 mm (2.8 in.)
L Maximum Rollback at Ground Level	37 deg.	37 deg.
M Maximum Rollback, Boom Fully Raised	65 deg.	65 deg.
N Maximum Bucket Dump Angle, Fully Raised	40 deg.	40 deg.
O Turning Circle Radius Over Outside of Bucket Edge	4.23 m (13 ft. 11 in.)	4.30 m (14 ft. 1 in.)
P Bucket Width	1.90 m (6 ft. 3 in.)	2.20 m (7 ft. 3 in.)
Q Tread Width (standard) ⁶	1397 mm (4 ft. 7 in.)	1397 mm (4 ft. 7 in.)
R Width Over Tires (standard) ⁶	1760 mm (5 ft. 9 in.)	1760 mm (5 ft. 9 in.)
⁶ Also see Tires/Wheels section on page 13.		
Specifications with ISO Parallel-Pin "Euro" Coupler and Bucket		
Capacity, Heaped	0.8 m ³ (1.0 cu. yd.)	1.1 m ³ (1.4 cu. yd.)
Capacity, Struck	0.66 m ³ (0.86 cu. yd.)	0.90 m ³ (1.18 cu. yd.)
Breakout Force	4690 kg (10,340 lb.)	3770 kg (8,311 lb.)
Tipping Load, Straight	3900 kg (8,598 lb.)	3550 kg (7,826 lb.)
Tipping Load, 40-deg. Full Turn	3450 kg (7,606 lb.)	3130 kg (6,900 lb.)
Rated Operating Load, 50% of Full-Turn Tipping Load (conforms to ISO 14397-1)*	1725 kg (3,803 lb.)	1565 kg (3,450 lb.)

*Rated operating capacity based on Deere attachments only.

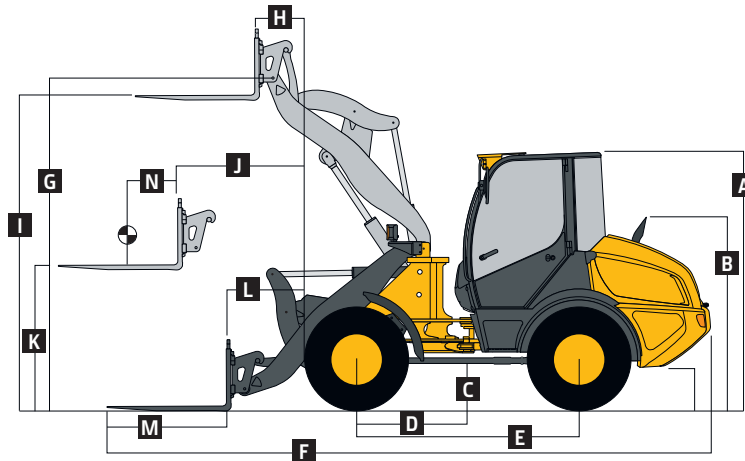

204L LOADER WITH ISO PARALLEL-PIN "EURO" COUPLER AND FORK

Dimensions with ISO Parallel-Pin "Euro" Coupler and Fork

1.22-m (48 in.) tine length

A	Height to Top of Cab	2.45 m (7 ft. 11 in.)
B	Height to Top of Exhaust	1.80 m (5 ft. 11 in.)
C	Ground Clearance	318 mm (12.5 in.)
D	Length from Centerline to Front Axle	1067 mm (3 ft. 6 in.)
E	Wheelbase	2.15 m (7 ft. 1 in.)
F	Overall Length, Forks on Ground	5.90 m (19 ft. 4 in.)
G	Height to Hinge Pin, Fully Raised	3.18 m (10 ft. 5 in.)
H	Reach, Fully Raised	450 mm (18 in.)
I	Fork Height, Fully Raised	3.00 m (9 ft. 10 in.)
J	Maximum Reach, Fork Level	1.22 m (4 ft. 0 in.)
K	Fork Height, Maximum Reach	1.37 m (4 ft. 6 in.)
L	Reach, Ground Level	780 mm (31 in.)
M	Tine Length	1.22 m (48 in.)
N	Load Position, 50% Tine Length	0.61 m (24 in.)

Specifications with ISO Parallel-Pin "Euro" Coupler and Fork

As measured with fork level, centered on tine

Tipping Load, Straight	3200 kg (7,055 lb.)
Tipping Load, 40-deg. Full Turn	2800 kg (6,173 lb.)
Rated Operating Load, 50% Full-Turn Tipping Load (conforms to ISO 14397-1 and SAE J1197)*	1400 kg (3,086 lb.)†
Rated Operating Load, Rough Terrain, 60% Full-Turn Tipping Load (conforms to EN474-3)*	1680 kg (3,704 lb.)†
Rated Operating Load, Firm and Level Ground, 80% Full-Turn Tipping Load (conforms to EN474-3)*	2000 kg (4,409 lb.)†

*Rated operating capacity based on Deere attachments only.

†Payload on forks is limited by tilt cylinder.

Bucket Selection Guide*

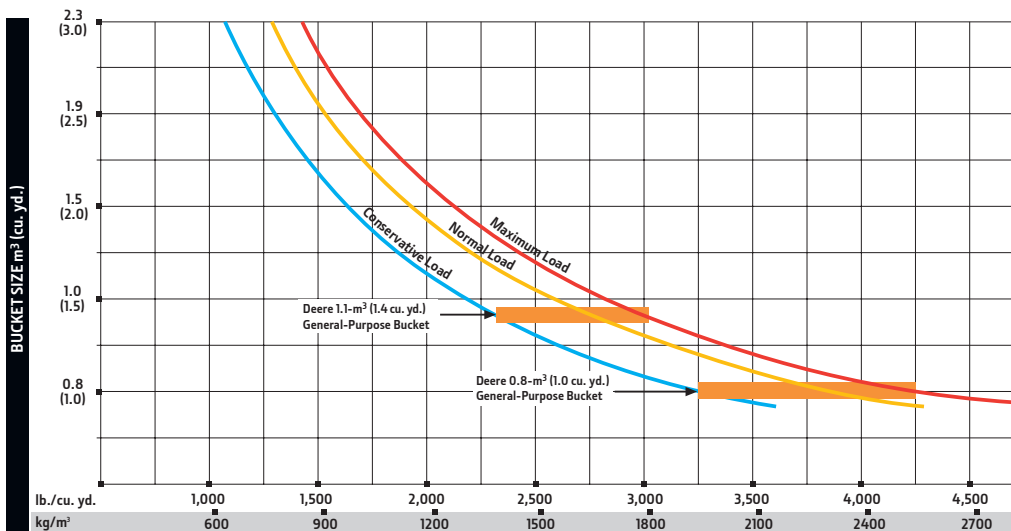

LOOSE MATERIALS	kg/m³	lb./cu. yd.
Chips, pulpwood	288	486
Cinders (coal, ashes, clinkers)	673	1,134
Clay and gravel, dry	1602	2,700
Clay, compact, solid	1746	2,943
Clay, dry in lump loose	1009	1,701
Clay, excavated in water	1282	2,160
Coal, anthracite, broken, loose	865	1,458
Coal, bituminous, moderately wet	801	1,350
Earth, common loam, dry	1218	2,052
Earth, mud, packed	1843	3,105
Granite, broken	1538	2,592
Gypsum	2275	3,834
Limestone, coarse, sized	1570	2,646
Limestone, mixed sizes	1682	2,835
Limestone, pulverized or crushed	1362	2,295
Sand, damp	2083	3,510
Sand, dry	1762	2,970
Sand, voids, full of water	2083	3,510
Sandstone, quarried	1314	2,214
Shale, broken crushed	1362	2,295
Slag, furnace granulated	1955	3,294
Stone or gravel, 375 to 875-mm (1.5 to 3.5") size	1442	2,430
Stone or gravel, 1875-mm (3/4") size	1602	2,700

* This guide, representing bucket sizes not necessarily manufactured by Deere, will help you in selecting proper bucket size for material density, loader configuration, and operating conditions. Optimum bucket size is determined after adding or subtracting all tipping load changes due to optional equipment. The "conservative load" line on this guide is recommended when operating in conditions such as soft ground and uneven surfaces. The "maximum load" condition on this guide is sometimes utilized when operating on firm ground and level surfaces.



304L SPECIFICATIONS

Engine	304L
Manufacturer and Model	Yanmar 4TNV98
Non-Road Emission Standard	EPA Final Tier 4 (FT4)
Cylinders	4
Valves per Cylinder	4
Displacement	3.3 L (203 cu. in.)
Net Peak Power at 2,400 rpm (ISO 9249 and SAE J1349)	48 kW (65 hp)
Gross Rated Power at 2,400 rpm (ISO 14396)	50 kW (68 hp)
Peak Torque at 1,600 rpm (ISO 9249 and SAE J1349)	237 Nm (175 lb.-ft.)
Engine Bore and Stroke	98 x 110 mm (3.89 x 4.33 in.)
Lubrication	Pressure system with full-flow spin-on filter
Fuel System	High-pressure common rail
Aspiration	Naturally aspirated
Air Cleaner	Dual safety element dry type
Cooling	
Fan	Direct driven
Engine Coolant Rating	-37 deg. C (-34 deg. F)
Powertrain	
Type	Hydrostatic (HST) with infinitely variable speed control over full range of operating speeds; 2 speed ranges; joystick-mounted F-N-R; acceleration pedal; HST inching pedal, which allows infinitely reduced travel speeds while maintaining full engine rpm and hydraulic flow
2 Travel Speeds in Forward and Reverse (equipped with 405/70R18 tires)	
Gear 1	6.0 km/h (3.7 mph)
Gear 2	20.0 km/h (12.0 mph)
Axles	Rigid-mount front and rear axles with 10-deg. frame oscillation
Rear Axle Oscillation Versus Front Axle	20 deg. total, stop to stop
Differentials	45% locking front and rear differentials
Maximum Rise and Fall, Single Wheel	254 mm (10 in.)
Steering	Hydraulic power steering (SAE J1511); 40-deg. articulation left and right
Steering Wheel Turns, Stop to Stop	3.5 left to 4.5 right
Articulation Angle	80-deg. arc (40 deg. each direction)
Final Drive	Heavy-duty outboard planetary
Brakes (SAE J1473 and ISO 3450)	
Service Brakes	Hydraulically actuated, self-adjusting internal wet-disc brake and driveline drum brake
Parking Brake	Automatically spring-applied, hydraulically released, internal wet disc
Hydraulics	
Main Pump (loader and steering)	Fixed-displacement gear pump; open-center system
Maximum Rated Flow at 6895 kPa (1,000 psi) and 2,400 rpm	77 L/m (20 gpm)
System Relief Pressure	
Loader	23 000 kPa (3,335 psi)
Steering	18 002 kPa (2,611 psi)
Hydraulic Cycle Time	
Raise	6.6 sec.
Dump	1.6 sec.
Lower (float down)	5.7 sec.
Lower (power down)	5.3 sec.
Total	13.5 sec.
Controls	3-function valve with single-lever control for boom and bucket, with hydraulic lockout feature; joystick-mounted push-button electrohydraulic (EH) control for auxiliary hydraulics, with hydraulic lockout feature; ride control electrically actuated for improved ride quality (factory and field option)
Cylinders	
Type	Heat-treated, chrome-plated, polished cylinder rods; hardened steel (replaceable bushings) pivot pins
Electrical	
Type	Electrical load center with blade-type multi-fused circuits
Voltage	12 volt
Number of Batteries	1
Battery Capacity	850 CCA
Reserve Capacity	80 min.
Alternator Rating	80 amp
Lights (SAE 99)	Driving/front working lights (2), rear working lights (2), turn signals, flashers, and stop- and taillights

304L SPECIFICATIONS



Operator's Station		304L	
Noise Level			
Operator Ear		78 dba	
Bystander		101 dba	
Tires/Wheels			
Tires on Single-Piece Rims	Tread Width*	Width Over Tires†	Change in Vertical Height
405/70R18 Firestone Duraforce (standard)	1427 mm (4 ft. 8 in.)	1790 mm (5 ft. 10 in.)	—
400/70R20 Michelin XMCL (optional)	1376 mm (4 ft. 6 in.)	1790 mm (5 ft. 10 in.)	+20 mm (+0.8 in.)
405/70R20 Mitas EM-01 (optional)	1376 mm (4 ft. 6 in.)	1790 mm (5 ft. 10 in.)	-1 mm (0 in.)
*Also see Q in Dimensions section on pages 20 and 22. / †Also see R in Dimensions section on pages 20 and 22.			
Serviceability			
Refill Capacities			
Cooling System (engine and radiator)		12.0 L (12.7 qt.)	
Differential and Planetary Axle			
Front		6.0 L (6.4 qt.)	
Rear		6.0 L (6.4 qt.)	
Engine Oil with Filter		10.0 L (10.8 qt.)	
Fuel Tank		50.0 L (13.2 gal.)	
Hydraulic/HST Reservoir with Filter		90.0 L (23.8 gal.)	
HST Motor Gearbox		1.0 L (1.1 qt.)	
Operating Weights			
With standard equipment, 405/70R18 tires, standard counterweight, 79-kg (175 lb.) operator, and full fuel tank			
	<i>With Enclosed Cab</i>	<i>With Canopy ROPS</i>	
Quik-Tatch™ Quick-Coupler			
With 0.8-m ³ (1.0 cu. yd.) Stockpiling/General-Purpose Bucket with Bolt-On Edge	5796 kg (12,778 lb.)	5676 kg (12,513 lb.)	
With 1.1-m ³ (1.4 cu. yd.) Stockpiling/General-Purpose Bucket with Bolt-On Edge	5906 kg (13,021 lb.)	5786 kg (12,756 lb.)	
With 1.6-m ³ (2.1 cu. yd.) Light-Material Bucket with Bolt-On Edge	5991 kg (13,208 lb.)	5871 kg (12,943 lb.)	
With Fork	5702 kg (12,571 lb.)	5582 kg (12,306 lb.)	
ISO Quick-Coupler			
With 0.8-m ³ (1.0 cu. yd.) Stockpiling/General-Purpose Bucket with Bolt-On Edge	5591 kg (12,326 lb.)	5471 kg (12,061 lb.)	
With 1.1-m ³ (1.4 cu. yd.) Stockpiling/General-Purpose Bucket with Bolt-On Edge	5690 kg (12,544 lb.)	5570 kg (12,280 lb.)	
With 1.6-m ³ (2.1 cu. yd.) Light-Material Bucket with Bolt-On Edge	5768 kg (12,716 lb.)	5648 kg (12,452 lb.)	
With Fork	5470 kg (12,059 lb.)	5350 kg (11,795 lb.)	
Optional Components			
Quik-Tatch Quick-Coupler			
With 0.8-m ³ (1.0 cu. yd.) Stockpiling/General-Purpose Bucket with Bolt-On Edge	535 kg (1,179 lb.)	535 kg (1,179 lb.)	
With 1.1-m ³ (1.4 cu. yd.) Stockpiling/General-Purpose Bucket with Bolt-On Edge	645 kg (1,421 lb.)	645 kg (1,421 lb.)	
With 1.6-m ³ (2.1 cu. yd.) Light-Material Bucket with Bolt-On Edge	730 kg (1,609 lb.)	730 kg (1,609 lb.)	
With Fork Frame and Forks (Class 3B)	336 kg (741 lb.)	336 kg (741 lb.)	
ISO Quick-Coupler			
With 0.8-m ³ (1.0 cu. yd.) Stockpiling/General-Purpose Bucket with Bolt-On Edge	330 kg (728 lb.)	330 kg (728 lb.)	
With 1.1-m ³ (1.4 cu. yd.) Stockpiling/General-Purpose Bucket with Bolt-On Edge	429 kg (946 lb.)	429 kg (946 lb.)	
With 1.6-m ³ (2.1 cu. yd.) Light-Material Bucket with Bolt-On Edge	507 kg (1,118 lb.)	507 kg (1,118 lb.)	
With Fork Frame and Forks (Class 2)	240 kg (529 lb.)	240 kg (529 lb.)	

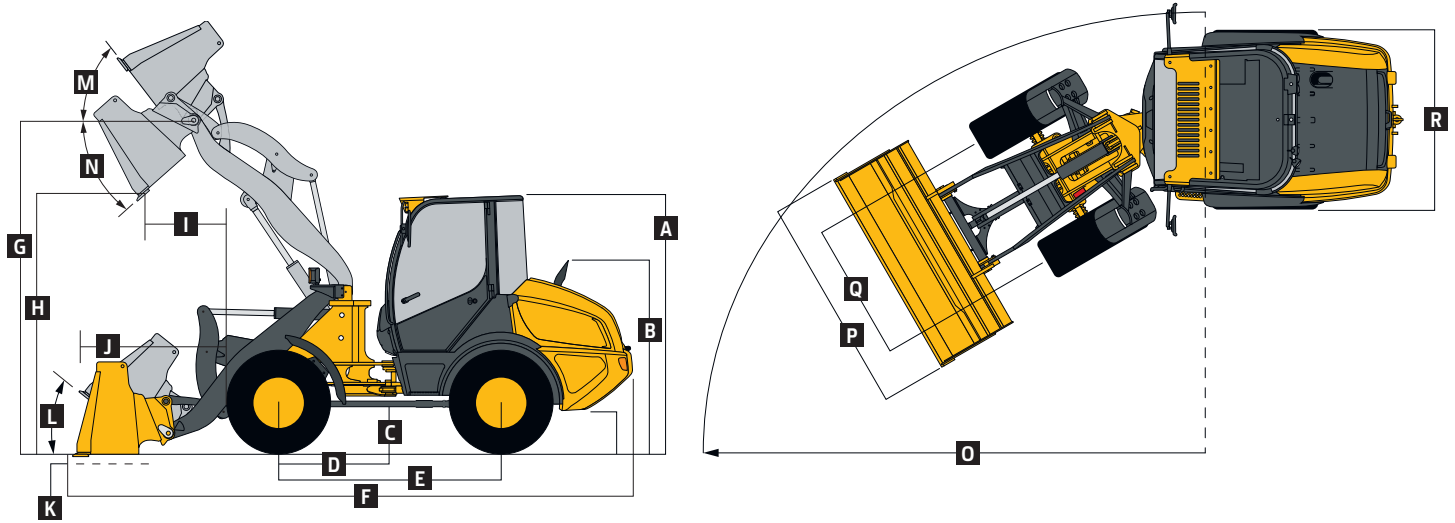

304L LOADER WITH QUIK-TATCH COUPLER AND BUCKET

Dimensions with Quik-Tatch Coupler and Bucket	0.8-m ³ (1.0 cu. yd.) stockpiling/ general purpose with bolt-on edge	1.1-m ³ (1.4 cu. yd.) stockpiling/ general purpose with bolt-on edge	1.6-m ³ (2.1 cu. yd.) light-material with bolt-on edge
A Height to Top of Cab	2.47 m (8 ft. 0 in.)	2.47 m (8 ft. 0 in.)	2.47 m (8 ft. 0 in.)
B Height to Top of Exhaust	1.82 m (5 ft. 11 in.)	1.82 m (5 ft. 11 in.)	1.82 m (5 ft. 11 in.)
C Ground Clearance	330 mm (13 in.)	330 mm (13 in.)	330 mm (13 in.)
D Length from Centerline to Front Axle	1067 mm (3 ft. 6 in.)	1067 mm (3 ft. 6 in.)	1067 mm (3 ft. 6 in.)
E Wheelbase	2.15 m (7 ft. 1 in.)	2.15 m (7 ft. 1 in.)	2.15 m (7 ft. 1 in.)
F Overall Length, Bucket on Ground	5.52 m (18 ft. 1 in.)	5.62 m (18 ft. 5 in.)	5.75 m (18 ft. 10 in.)
G Height to Hinge Pin, Fully Raised	3.37 m (11 ft. 1 in.)	3.37 m (11 ft. 1 in.)	3.37 m (11 ft. 1 in.)
H Dump Clearance, 40-deg. Full Height	2.62 m (8 ft. 7 in.)	2.57 m (8 ft. 5 in.)	2.49 m (8 ft. 2 in.)
I Reach, 40-deg. Dump, Full Height	930 mm (3 ft. 1 in.)	975 mm (3 ft. 2 in.)	1055 mm (3 ft. 5 in.)
J Reach, 42-deg. Dump, 2.13-m (7 ft.) Clearance	1.60 m (5 ft. 4 in.)	1.65 m (5 ft. 6 in.)	1.69 m (5 ft. 7 in.)
K Maximum Digging Depth	70 mm (2.8 in.)	70 mm (2.8 in.)	70 mm (2.8 in.)
L Maximum Rollback at Ground Level	37 deg.	37 deg.	37 deg.
M Maximum Rollback, Boom Fully Raised	65 deg.	65 deg.	65 deg.
N Maximum Bucket Dump Angle, Fully Raised	40 deg.	40 deg.	40 deg.
O Turning Circle Radius Over Outside of Bucket Edge	4.47 m (14 ft. 8 in.)	4.53 m (14 ft. 10 in.)	4.56 m (15 ft. 0 in.)
P Bucket Width	1.90 m (6 ft. 3 in.)	2.20 m (7 ft. 3 in.)	2.40 m (7 ft. 10 in.)
Q Tread Width (standard) ⁶	1427 mm (4 ft. 8 in.)	1427 mm (4 ft. 8 in.)	1427 mm (4 ft. 8 in.)
R Width Over Tires (standard) ⁶	1790 mm (5 ft. 10 in.)	1790 mm (5 ft. 10 in.)	1790 mm (5 ft. 10 in.)

⁶Also see **Tires/Wheels** section on page 19.

Specifications with Quik-Tatch Coupler and Bucket

Capacity, Heaped	0.8 m ³ (1.0 cu. yd.)	1.1 m ³ (1.4 cu. yd.)	1.6 m ³ (2.1 cu. yd.)
Capacity, Struck	0.66 m ³ (0.86 cu. yd.)	0.90 m ³ (1.18 cu. yd.)	1.40 m ³ (1.80 cu. yd.)
Breakout Force	5370 kg (11,839 lb.)	4790 kg (10,560 lb.)	4120 kg (9,083 lb.)
Tipping Load, Straight	4000 kg (9,171 lb.)	4000 kg (8,818 lb.)	3800 kg (8,378 lb.)
Tipping Load, 40-deg. Full Turn	3670 kg (8,091 lb.)	3600 kg (7,937 lb.)	3350 kg (7,385 lb.)
Rated Operating Load, 50% of Full-Turn Tipping Load (conforms to ISO 14397-1)*	1835 kg (4,046 lb.)	1800 kg (3,969 lb.)	1675 kg (3,693 lb.)

*Rated operating capacity based on Deere attachments only.

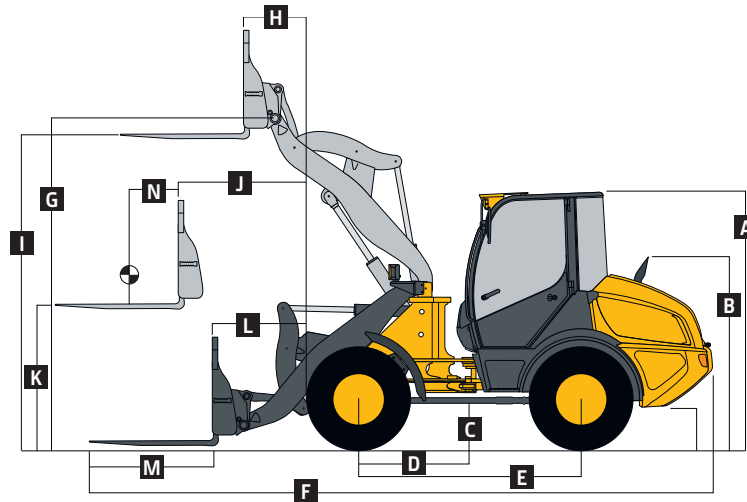

304L LOADER WITH QUIK-TATCH COUPLER AND FORK

Dimensions with Quik-Tatch Coupler and Fork

	<i>1.22-m (48 in.) tine length</i>	
A	Height to Top of Cab	2.47 m (8 ft. 0 in.)
B	Height to Top of Exhaust	1.82 m (5 ft. 11 in.)
C	Ground Clearance	330 mm (13 in.)
D	Length from Centerline to Front Axle	1067 mm (3 ft. 6 in.)
E	Wheelbase	2.15 m (7 ft. 1 in.)
F	Overall Length, Forks on Ground	5.96 m (19 ft. 7 in.)
G	Height to Hinge Pin, Fully Raised	3.37 m (11 ft. 1 in.)
H	Reach, Fully Raised	515 mm (20 in.)
I	Fork Height, Fully Raised	3.20 m (10 ft. 6 in.)
J	Maximum Reach, Fork Level	1.33 m (4 ft. 4 in.)
K	Fork Height, Maximum Reach	1.47 m (4 ft. 10 in.)
L	Reach, Ground Level	830 mm (33 in.)
M	Tine Length	1.22 m (48 in.)
N	Load Position, 50% Tine Length	0.61 m (24 in.)

Specifications with Quik-Tatch Coupler and Fork

As measured with fork level, centered on tine

	Tipping Load, Straight	3280 kg (7,231 lb.)
	Tipping Load, 40-deg. Full Turn	2900 kg (6,393 lb.)
	Rated Operating Load, 50% Full-Turn Tipping Load (conforms to ISO 14397-1 and SAE J1197)*	1450 kg (3,197 lb.) [†]
	Rated Operating Load, Rough Terrain, 60% Full-Turn Tipping Load (conforms to EN474-3)*	1740 kg (3,836 lb.) [†]
	Rated Operating Load, Firm and Level Ground, 80% Full-Turn Tipping Load (conforms to EN474-3)*	2120 kg (4,674 lb.) [†]

*Rated operating capacity based on Deere attachments only.

[†]Payload on forks is limited by tilt cylinder.

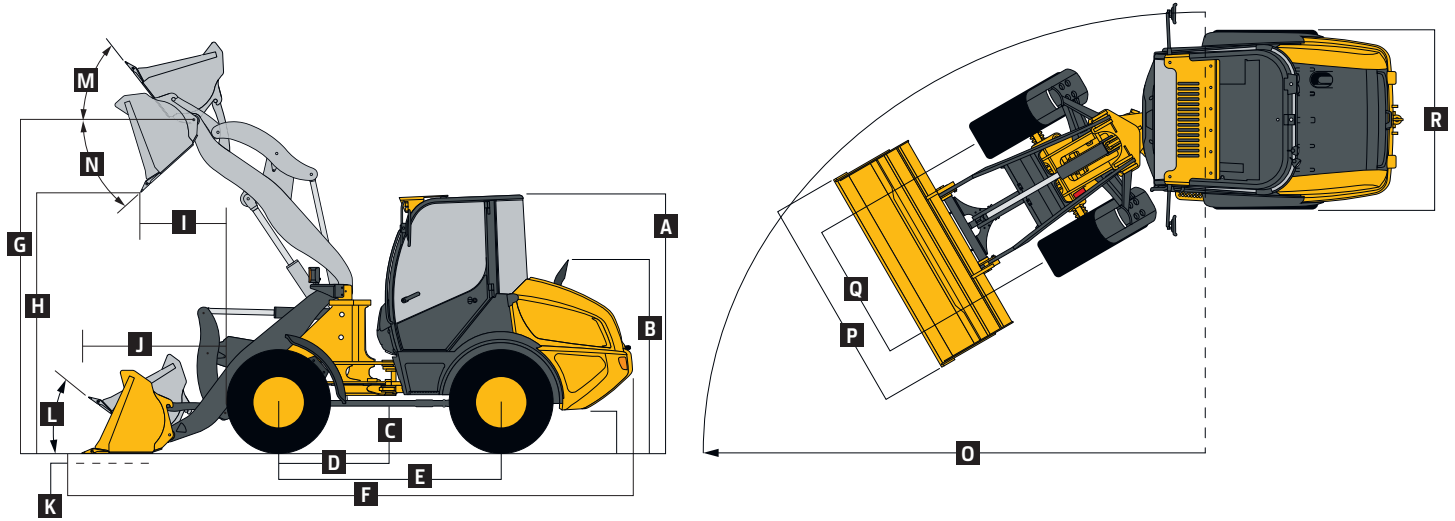

304L LOADER WITH ISO PARALLEL-PIN "EURO" COUPLER AND BUCKET

Dimensions with ISO Parallel-Pin "Euro" Coupler and Bucket	0.8-m ³ (1.0 cu. yd.) hook-on stockpiling/general purpose with bolt-on edge	1.1-m ³ (1.4 cu. yd.) hook-on stockpiling/general purpose with bolt-on edge	1.6-m ³ (2.1 cu. yd.) hook-on light-material with bolt-on edge
A Height to Top of Cab	2.47 m (8 ft. 0 in.)	2.47 m (8 ft. 0 in.)	2.47 m (8 ft. 0 in.)
B Height to Top of Exhaust	1.82 m (5 ft. 11 in.)	1.82 m (5 ft. 11 in.)	1.82 m (5 ft. 11 in.)
C Ground Clearance	330 mm (13 in.)	330 mm (13 in.)	330 mm (13 in.)
D Length from Centerline to Front Axle	1067 mm (3 ft. 6 in.)	1067 mm (3 ft. 6 in.)	1067 mm (3 ft. 6 in.)
E Wheelbase	2.15 m (7 ft. 1 in.)	2.15 m (7 ft. 1 in.)	2.15 m (7 ft. 1 in.)
F Overall Length, Bucket on Ground	5.52 m (18 ft. 1 in.)	5.62 m (18 ft. 5 in.)	5.75 m (18 ft. 10 in.)
G Height to Hinge Pin, Fully Raised	3.37 m (11 ft. 1 in.)	3.37 m (11 ft. 1 in.)	3.37 m (11 ft. 1 in.)
H Dump Clearance, 40-deg. Full Height	2.62 m (8 ft. 7 in.)	2.57 m (8 ft. 5 in.)	2.49 m (8 ft. 2 in.)
I Reach, 40-deg. Dump, Full Height	930 mm (3 ft. 1 in.)	975 mm (3 ft. 2 in.)	1055 mm (3 ft. 5 in.)
J Reach, 42-deg. Dump, 2.13-m (7 ft.) Clearance	1.60 m (5 ft. 4 in.)	1.65 m (5 ft. 6 in.)	1.69 m (5 ft. 7 in.)
K Maximum Digging Depth	70 mm (2.8 in.)	70 mm (2.8 in.)	70 mm (2.8 in.)
L Maximum Rollback at Ground Level	37 deg.	37 deg.	37 deg.
M Maximum Rollback, Boom Fully Raised	65 deg.	65 deg.	65 deg.
N Maximum Bucket Dump Angle, Fully Raised	40 deg.	40 deg.	40 deg.
O Turning Circle Radius Over Outside of Bucket Edge	4.47 m (14 ft. 8 in.)	4.53 m (14 ft. 10 in.)	4.55 m (14 ft. 11 in.)
P Bucket Width	1.90 m (6 ft. 3 in.)	2.20 m (7 ft. 3 in.)	2.40 m (7 ft. 10 in.)
Q Tread Width (standard) [§]	1427 mm (4 ft. 8 in.)	1427 mm (4 ft. 8 in.)	1427 mm (4 ft. 8 in.)
R Width Over Tires (standard) [§]	1790 mm (5 ft. 10 in.)	1790 mm (5 ft. 10 in.)	1790 mm (5 ft. 10 in.)

[§]Also see **Tires/Wheels** section on page 19.

Specifications with ISO Parallel-Pin "Euro" Coupler and Bucket

Capacity, Heaped	0.8 m ³ (1.0 cu. yd.)	1.1 m ³ (1.4 cu. yd.)	1.6 m ³ (2.1 cu. yd.)
Capacity, Struck	0.66 m ³ (0.86 cu. yd.)	0.90 m ³ (1.18 cu. yd.)	1.40 m ³ (1.80 cu. yd.)
Breakout Force	5370 kg (11,839 lb.)	5710 kg (12,588 lb.)	4120 kg (9,083 lb.)
Tipping Load, Straight	4000 kg (9,171 lb.)	4400 kg (9,700 lb.)	3800 kg (8,378 lb.)
Tipping Load, 40-deg. Full Turn	3670 kg (8,091 lb.)	3850 kg (8,488 lb.)	3350 kg (7,385 lb.)
Rated Operating Load, 50% of Full-Turn Tipping Load (conforms to ISO 14397-1)*	1835 kg (4,046 lb.)	1925 kg (4,244 lb.)	1675 kg (3,693 lb.)

*Rated operating capacity based on Deere attachments only.

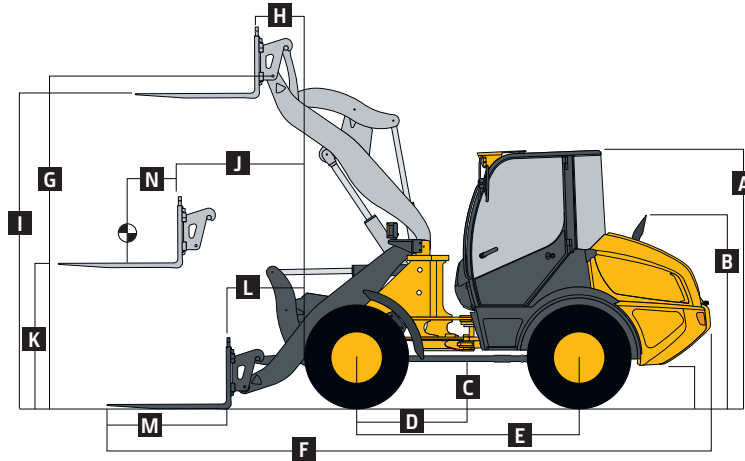

304L LOADER WITH ISO PARALLEL-PIN "EURO" COUPLER AND FORK

Dimensions with ISO Parallel-Pin "Euro" Coupler and Fork	<i>1.22-m (48 in.) tine length</i>
A Height to Top of Cab	2.47 m (8 ft. 0 in.)
B Height to Top of Exhaust	1.82 m (5 ft. 11 in.)
C Ground Clearance	330 mm (13 in.)
D Length from Centerline to Front Axle	1067 mm (3 ft. 6 in.)
E Wheelbase	2.15 m (7 ft. 1 in.)
F Overall Length, Forks on Ground	5.94 m (19 ft. 6 in.)
G Height to Hinge Pin, Fully Raised	3.37 m (11 ft. 1 in.)
H Reach, Fully Raised	515 mm (20 in.)
I Fork Height, Fully Raised	3.20 m (10 ft. 6 in.)
J Maximum Reach, Fork Level	1.33 m (4 ft. 4 in.)
K Fork Height, Maximum Reach	1.47 m (4 ft. 10 in.)
L Reach, Ground Level	830 mm (33 in.)
M Tine Length	1.22 m (48 in.)
N Load Position, 50% Tine Length	0.61 m (24 in.)
Specifications with ISO Parallel-Pin "Euro" Coupler and Fork	<i>As measured with fork level, centered on tine</i>
Tipping Load, Straight	3500 kg (7,716 lb.)
Tipping Load, 40-deg. Full Turn	3100 kg (6,834 lb.)
Rated Operating Load, 50% Full-Turn Tipping Load (conforms to ISO 14397-1 and SAE J1197)*	1550 kg (3,417 lb.) [†]
Rated Operating Load, Rough Terrain, 60% Full-Turn Tipping Load (conforms to EN474-3)*	1850 kg (4,079 lb.) [†]
Rated Operating Load, Firm and Level Ground, 80% Full-Turn Tipping Load (conforms to EN474-3)*	2400 kg (5,291 lb.) [†]

*Rated operating capacity based on Deere attachments only.

[†]Payload on forks is limited by tilt cylinder.

Bucket Selection Guide*

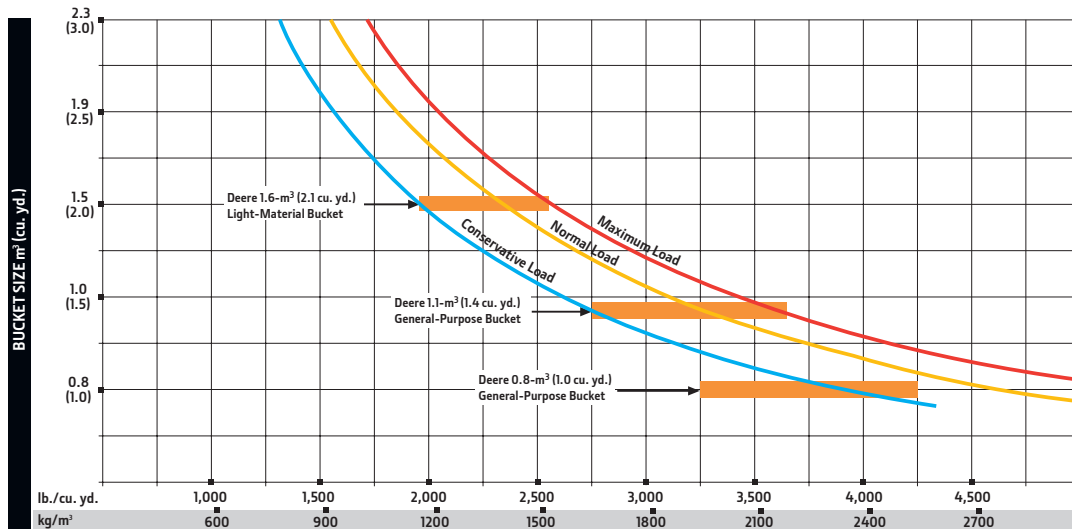

LOOSE MATERIALS	kg/m³	lb./cu. yd.
Chips, pulpwood	288	486
Cinders (coal, ashes, clinkers)	673	1,134
Clay and gravel, dry	1602	2,700
Clay, compact, solid	1746	2,943
Clay, dry in lump loose	1009	1,701
Clay, excavated in water	1282	2,160
Coal, anthracite, broken, loose	865	1,458
Coal, bituminous, moderately wet	801	1,350
Earth, common loam, dry	1218	2,052
Earth, mud, packed	1843	3,105
Granite, broken	1538	2,592
Gypsum	2275	3,834
Limestone, coarse, sized	1570	2,646
Limestone, mixed sizes	1682	2,835
Limestone, pulverized or crushed	1362	2,295
Sand, damp	2083	3,510
Sand, dry	1762	2,970
Sand, voids, full of water	2083	3,510
Sandstone, quarried	1314	2,214
Shale, broken crushed	1362	2,295
Slag, furnace granulated	1955	3,294
Stone or gravel, 375 to 875-mm (1.5 to 3.5") size	1442	2,430
Stone or gravel, 18.75-mm (3/4") size	1602	2,700

*This guide, representing bucket sizes not necessarily manufactured by Deere, will help you in selecting proper bucket size for material density, loader configuration, and operating conditions. Optimum bucket size is determined after adding or subtracting all tipping load changes due to optional equipment. The "conservative load" line on this guide is recommended when operating in conditions such as soft ground and uneven surfaces. The "maximum load" condition on this guide is sometimes utilized when operating on firm ground and level surfaces.

Additional equipment

Key: ● Standard ▲ Optional or special

See your John Deere dealer for further information.

204L	304L	Engine
●	●	Antifreeze, -37 deg. C (-34 deg. F)
●	●	Coolant recovery tank
●	●	Fan safety guard
●	●	Fan, sucker type, direct drive
●	●	Under-hood aftertreatment (including diesel oxidation catalyst and diesel particulate filter)
●	●	Environmentally friendly engine oil drain
●	●	Engine oil cooler
●	●	Quick-release fuel filter and water separator
●	●	Automatic engine glow plugs for cold start
▲	▲	Engine coolant heater, 1,000 watts, 110 volts
		Electrical
●	●	Starter switch with electric fuel cutoff
●	●	12-volt system
●	●	Electrical load center: Blade-type fuses
●	●	Standard battery (1), 12 volt with 850 CCA, 80-min. reserve
●	●	Master electrical disconnect switch
●	●	Alternator, 12 volts, 80 amps
●	●	Horn (conforms to SAE J994 / J1446)
●	●	Lights (conform to SAE 99): Driving / Turn signals / Flashers / Stop / Taillights
●	●	Worklights, front (2)
●	●	Worklights, rear (2)
●	●	Reverse warning alarm (conforms to SAE J994 / J1446)
●	●	Multifunction monitor with audible and visual warnings: Engine coolant temperature and hydraulic oil temperature / Gauge: Fuel / Visual indicators: Air-filter restriction, low voltage, coolant temperature, engine oil pressure, engine preheat, engine rpm, hydraulic bucket return-to-dig control, hydraulic oil temperature, lights high beam, park brake, turn signals, fuel-level gauge, and hour meter

204L	304L	Electrical (continued)
●	●	Indicator lights: Engine air filter/ Battery voltage / Parking brake actuated / Forward/reverse travel / 1st- or 2nd-speed range / Turn signal and hazard lights / High-beam driving lights
●	●	Radio-ready cab, fused 12-volt radio electrical lead and speakers, power port
●	●	Pre-wired for roof beacon
		Powertrain/Brakes
●	●	Hydrostatic (HST) transmission: Electric shift control / Single-lever joystick F-N-R / Hydrostatic oil cooler / Inching pedal / 2 speeds forward and reverse / Infinitely variable speed control
●	●	Parking brake, spring applied, hydraulically released, switch operated
●	●	45% limited-slip front and rear differentials
		Hydraulic System
●	●	Hydraulic system oil cooler
●	●	Float detent
●	●	Reservoir sight gauge
●	●	Fine-micron hydraulic filters, vertical mounting
●	●	Hydraulic function lockout
●	●	3-function hydraulic valve with electrohydraulic push-button 3rd-function control
●	●	Quick-coupler diagnostic ports: Priority pressure / Hydraulic pump pressure / Control valve pressure / HST pressure
		Operator's Station
▲	▲	Cab (conforms to SAE J1040, SAE J231, ISO 3471, and ISO 3449): Air conditioner/heater/defroster / Tilt steering / Inside mirror
●	●	Canopy
●	●	Storage compartment for operator's manual and other items

204L	304L	Operator's Station (continued)
●	●	Rubber floor mat
●	●	Rearview mirrors, outside (2)
●	●	Handholds and steps, ergonomically located and slip resistant (conform to SAE J185)
		Loader Linkage
●	●	Z-bar loader linkage provides high bucket breakout
●	●	Loader boom service locking bar (conforms to SAE J38)
		Buckets and Attachments
▲	▲	Full line of buckets with selection of bolt-on cutting edges
▲	▲	Electrically actuated quick-coupler with flags
▲	▲	Full line of construction utility forks, pallet forks, and other attachments*
▲	▲	ISO parallel-pin hydraulically actuated coupler
		Tires
●	●	365/70R18 Mitas EM-01
▲	▲	400/70R20 Michelin XMCL
▲	▲	405/70R18 Firestone Duraforce
	▲	405/70R20 Mitas EM-01
		Other
●	●	Fenders, front and rear
●	●	Articulation locking bar (conforms to SAE J276)
●	●	Vandal protection, includes lockable engine enclosure
●	●	Counterweight, saddle-type, built-in
●	●	Rear bottom guard, built-in
●	●	Drawbar, with locking pin
●	●	Lift eyes
●	●	Tie-downs
▲	▲	Fire extinguisher
▲	▲	Material-weighing system†
▲	▲	Ride control
▲	▲	Creep control
▲	▲	JDLINK™ wireless communication system (available in specific countries; see your dealer for details)

*See your John Deere dealer for further information.

†Contact LOAD-RITE™.

Net engine power is with standard equipment including air cleaner, exhaust system, alternator, and cooling fan, at test conditions specified per ISO 9249. No derating is required up to 3000-m (10,000 ft.) altitude. Specifications and design subject to change without notice. Wherever applicable, specifications are in accordance with SAE standards. Except where otherwise noted, these specifications are based on units with all standard equipment, ROPS cab, standard rear counterweight, full fuel tank, and 79-kg (175 lb.) operator; 204L unit with 365/70R18 tires; and 304L unit with 405/70R18 tires.

