

333G

Compact Track Loader



JOHN DEERE



GET ON THE WINNING TRACK

When we asked owners and operators like you — the ones who run them — for your ideas on what makes a great compact track loader, you helped us redefine our proven G-Series models. You wanted more power under the hood. And increased lift height, reach, stability, and breakout force. Plus optional LED side lighting, rearview camera, anti-vibration undercarriage system, and flexible grade-control solutions including fully integrated SmartGrade™. Putting us through the paces has helped put the 333G on track for even more performance — and your operation in the running for some pretty big wins.

Armed forces

Extreme pushing power and bucket breakout forces deliver the tractive effort and leverage to carve out clay, plow through piles, and handle large loads.

Smooth operator

Optional anti-vibration undercarriage system* allows higher travel speeds over rough terrain with better material retention and lower operator fatigue. Bogie system enables smoother transitions over uneven surfaces.

*Only for zigzag-bar tracks; not compatible with SmartGrade or SmartGrade with Slope Control.

Put production on repeat

Optional electrohydraulic (EH) boom performance package shortens cycle times and speeds production in repetitive boom applications.

Load warrior

Height to hinge pin of 11 feet enables the 333G to easily load tandem-axle dump trucks, fill hoppers, and feed mixers. Additional reach comes in handy for moving pallets of pavers or other weighty cargo.

Take control your way

EH ISO-pattern joystick controls that allow customized machine operations based on operator preference come standard. EH four-way controls, including EH foot control, ISO joystick control, H-pattern joystick control, and ISO and foot controls, are optional.



+



RELIABLE

PRODUCTIVE

333G COMPACT TRACK LOADER



GRADE IT EASY

WITH JOHN DEERE GRADE-CONTROL OPTIONS

- **Onboard grade-indication** provides a real-time readout of cross-slope (machine roll) and mainfall slope (machine pitch) on the in-cab monitor. Use relative value readout to alter grades relative to existing or reference grades.
- **Slope Control** lets operators automatically maintain blade position without using external lasers or GNSS, to hold grade with less effort, corrections, and adjustments. Laser option helps make Slope Control even more productive.
- The first CTL to feature fully integrated 3D-grade-control technology, the **333G SmartGrade** includes our operator-friendly DozerMode control system. Pushing a button on the sealed-switch module switches to the EH control pattern to enable intuitive crawler operation. Deere-designed and -built six-way SG96 Dozer Blade is tough enough to cut grade but can also smoothly spread or precisely fine-grade materials.

Packed for productivity

Low center of gravity, 35-degree bucket rollback, optional ride control, and optional hydraulic self-leveling help keep forks loaded and buckets full. Add capacity with up to three sets of rear counterweights.

Balanced by design

Longer track frames and optimized roller spacing improve balance and stability, to enhance agility and operator comfort compared to previous models.

Room with a view

Large cab entryway with swing-out door, generous foot- and legroom, sealing and pressurization to minimize dust and noise, and deluxe vinyl suspension seat optimize operator comfort. Easy-to-read LCD monitor reveals a wealth of vital operating info and advanced diagnostics.

Seeing is believing

Clear sightlines to the cutting edge and bucket corners, above and below the lift arms, and the jobsite ahead and behind instill confidence in close quarters. Optional LED side lighting and rearview camera further enhance visibility.

Within easy reach

Tilt the hood up for convenient ground-level access to the dipstick, filters, and fuel and fluid fills. Neat freaks and rental yards can appreciate the convenient cab-footwell access that helps speed cleaning.

Choose to connect

Equip your CTL with your choice of over 100 available John Deere attachments to expand the flexibility of your operation. Increased auxiliary hydraulic flow and power compared to previous models boosts attachment performance.



333G COMPACT TRACK LOADER



**SWITCHING ATTACHMENTS
ENABLES VERSATILITY IN
ANY WEATHER OR SEASON**

Safety first

Standard personal-protection features include in-cab-activated boom lock and triple-interlock system that detects the presence of the operator to help keep harm's way at bay.

Remote diagnostics and support

To maximize uptime and lower costs, JDLink™ connectivity provides machine location, utilization data, and alerts to help you maximize productivity and efficiency. JDLink also enables John Deere Connected Support™. Dealers use Expert Alerts based on data from thousands of connected machines to proactively address conditions that may otherwise likely lead to downtime. Your dealer can also monitor machine health and leverage remote diagnostics and programming capability to further diagnose problems and even update machine software without a time-consuming trip to the jobsite.*

*Availability varies by region. Options not available in every country.



333G COMPACT TRACK LOADER SPECIFICATIONS

Engine 333G / 333G SMARTGRADE™			
Manufacturer and Model	Yanmar 4TNV94FHT	Displacement	3.1 L (186.3 cu. in.)
Non-Road Emission Standards	EPA Final Tier 4/EU Stage IV	Rated Engine Speed	2,500 rpm
Cylinders	4	Torque Rise	39% at 1,700 rpm
Gross Rated Power (ISO 14396)	74.6 kW (100 hp) at 2,500 rpm	Aspiration	Turbocharged, intercooled
Net Peak Power (SAE J1349 / ISO 9249)	72.0 kW (96.6 hp) at 2,500 rpm	Air Cleaner	Dry dual element
Peak Torque	395 Nm (291.3 ft.-lb.) at 1,700 rpm		
Cooling			
Fan Type	Variable-speed hydraulic drive standard / reversing fan drive optional		
Powertrain			
Pump	Axial-piston hydrostatic	Travel Speeds (continued)	
Controls	Electrohydraulic	2 Speed, High	12.6 km/h (7.8 mph)
Travel Speeds		Brakes	Integral, automatic, spring-applied, hydraulically released wet-disc brake
2 Speed, Low	8.5 km/h (5.3 mph)		
Undercarriage			
Rubber Tracks	New-Generation smooth-ride long-life rubber with steel inserts	Ground Pressure (continued)	
Track Width		With Optional 400-mm (15.8 in.) Track	38.4 kPa (5.6 psi)
Standard	450 mm (17.7 in.)	Track Rollers (per side)	5 triple-flange smooth-ride all-steel rollers
Optional	400 mm (15.8 in.)	Track Idlers (per side)	2 double-flange smooth-ride all-steel rollers
Ground Pressure		Bearings/Seals (rollers/idlers)	Heavy-duty journal bearings and metal face seals
With Standard 450-mm (17.7 in.) Track	34.1 kPa (5.0 psi)	Tractive Effort	5221 kgf (11,500 lbf)
Hydraulics			
Pump Flow		Hydraulic Horsepower Flow (calculated)	
Standard	95 L/m (25.0 gpm)	Standard	38 kW (50 hp)
Total With High-Flow Option	156 L/m (41.1 gpm)	High	62 kW (83 hp)
System Pressure at Couplers	23 787 kPa (3,450 psi)		
Cylinders			
Type	John Deere heat-treated, chrome-plated, polished cylinder rods, hardened steel (replaceable bushings) pivot pins		
Electrical			
Voltage	12 volt	Lights	Halogen: 2 front and 1 rear standard / deluxe LED: 4 front and 1 rear optional
Battery Capacity	925 CCA		
Alternator Rating	90 amp		
Operator's Station		Serviceability	
ROPS (ISO 3471) / FOPS (ISO 3449) structure with quick-pivot standard		Refill Capacity	
		Fuel Tank	114 L (30 gal.)
Operating Weights			
	333G	333G SMARTGRADE	
With Standard 450-mm (17.7 in.) Track	5493 kg (12,100 lb.)	6356 kg (14,000 lb.) (includes 3 sets of counterweights and dozer blade)	
With Optional 400-mm (15.8 in.) Track	5448 kg (12,000 lb.)	6311 kg (13,900 lb.)	
Machine Dimensions			
A Length Without Bucket	3.10 m (122 in.) (10 ft. 2 in.)	3.10 m (122 in.) (10 ft. 2 in.)	
B Length With Foundry Bucket	3.71 m (146 in.) (12 ft. 2 in.)	3.71 m (146 in.) (12 ft. 2 in.)	
C Width Without Bucket			
With 400-mm (15.8 in.) Track	2.00 m (78.9 in.) (6 ft. 7 in.)	2.00 m (78.9 in.) (6 ft. 7 in.)	
With 450-mm (17.7 in.) Track	2.05 m (80.7 in.) (6 ft. 9 in.)	2.05 m (80.7 in.) (6 ft. 9 in.)	
D Height to Top of ROPS	2.20 m (86.7 in.) (7 ft. 3 in.)	2.30 m (90.5 in.) (7 ft. 7 in.) (including GNSS)	
E Height to Hinge Pin	3.35 m (132 in.) (11 ft. 0 in.)	3.35 m (132 in.) (11 ft. 0 in.)	
F Dump Height With Foundry Bucket	2.69 m (106.1 in.) (8 ft. 10 in.)	2.69 m (106.1 in.) (8 ft. 10 in.)	
G Dump Reach			
With Foundry Bucket	0.71 m (28 in.)	0.71 m (28 in.)	
With Construction Bucket (no edge)	0.88 m (34.6 in.)	0.88 m (34.6 in.)	
H Ground Clearance	0.24 m (9.4 in.)	0.24 m (9.4 in.)	
I Angle of Departure	31 deg.	31 deg.	
J Front Turn Radius With Foundry Bucket	2.18 m (85.7 in.) (7 ft. 2 in.)	2.18 m (85.7 in.) (7 ft. 2 in.)	
K Dump Angle (full lift height)	48 deg.	48 deg.	
L Bucket Rollback (ground level)	35 deg.	35 deg.	
Loader Performance			
Tipping Load With Foundry Bucket	4799 kg (10,570 lb.)	5280 kg (11,630 lb.)	
SAE Rated Operating Capacity			
At 35% Tipping Load	1680 kg (3,700 lb.)	1848 kg (4,071 lb.)	
At 50% Tipping Load	2399 kg (5,285 lb.)	2640 kg (5,815 lb.)	
Boom Breakout Force			
With Foundry Bucket	3746 kg (8,250 lb.)	3746 kg (8,250 lb.)	
With Construction Bucket	3519 kg (7,750 lb.)	3519 kg (7,750 lb.)	
Bucket Breakout Force			
With Foundry Bucket	6243 kg (13,750 lb.)	6243 kg (13,750 lb.)	
With Heavy-Duty Construction Bucket	4200 kg (9,250 lb.)	4200 kg (9,250 lb.)	

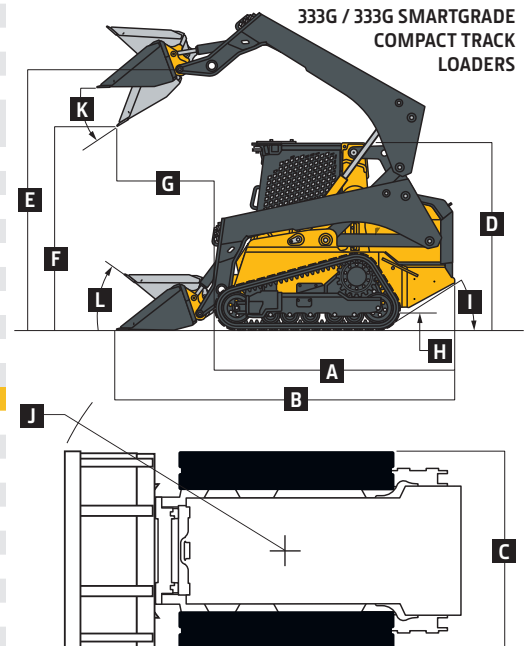

While general information, pictures, and descriptions are provided, some illustrations and text may include product options and accessories NOT AVAILABLE in all regions, and in some countries products and accessories may require modifications or additions to ensure compliance with the local regulations of those countries.

333G SmartGrade Dozer Dimensions

Blade Type	Power-Angle-Tilt (PAT)
M Blade Width	2440 mm (96 in.) (8 ft. 0 in.)
N Blade Height	740 mm (29 in.)
SAE Capacity	1.18 m ³ (1.54 cu. yd.)
Weight	640 kg (1,400 lb.)
O Blade Angle	±24 deg.
P Overall Width With Blade Angled	2258 mm (88 in.) (7 ft. 4 in.)
Q Blade Tilt	±8 deg.
R Cut Reach	
With 400-mm (15.8 in.) Narrow Track	15.3 mm (0.6 in.)
With 450-mm (17.7 in.) Wide Track	-22.2 mm (-0.8 in.)
S Width Over Track	
With 400-mm (15.8 in.) Narrow Track	2000 mm (78.9 in.) (6 ft. 6.9 in.)
With 450-mm (17.7 in.) Wide Track	2047 mm (80.7 in.) (6 ft. 8.7 in.)
T Cast Reach	
With 400-mm (15.8 in.) Narrow Track	246 mm (9.7 in.)
With 450-mm (17.7 in.) Wide Track	223.8 mm (8.8 in.)

333G SMARTGRADE COMPACT TRACK LOADER

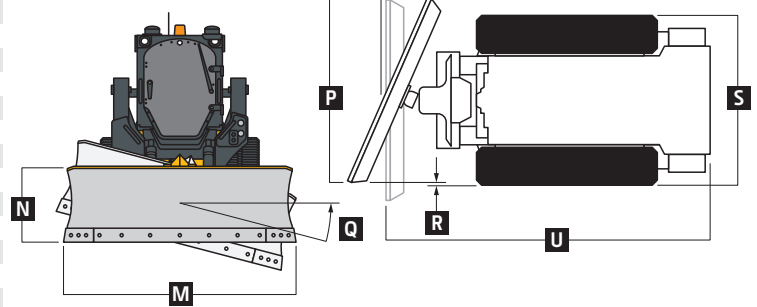

U Length With Dozer Blade Installed	
With 400-mm (15.8 in.) Narrow Track	3940 mm (155 in.) (12 ft. 11 in.)
With 450-mm (17.7 in.) Wide Track	3940 mm (155 in.) (12 ft. 11 in.)

Additional equipment

Key: ● Standard ▲ Optional or special

See your John Deere dealer for further information.

333G Engine

- Meets EPA Final Tier 4/EU Stage IV emissions
- Yanmar 4TNV94FHT
- Auto-idle
- Automatic fan tensioner
- Automatic preheat
- Electronic injection system
- ▲ Engine air precleaner kit
- Fuel tank, 114 L (30 gal.)
- John Deere COOL-GARD™ II Extended-Life Engine Coolant
- John Deere Plus-50™ 10w30 initial engine oil fill⁸
- 4-cylinder 74.6 kW (100 gross hp)/72.0 kW (96.6 net hp), 3.1-L (186.3 cu. in.) displacement
- 5-micron primary fuel filter and water separator
- ▲ Cold-weather starting package

Cooling System

- Coolant surge tank
- Variable-speed hydraulically driven fan cooling system
- ▲ Reversing fan drive

Powertrain

- High-torque heavy-duty planetary-reduction final drive
- Automatic spring-applied hydraulically released wet-disc park brake
- Wet-disc brakes
- Transmission, 2 speed

Hydraulic System

- John Deere hydraulic cylinders with cushioned boom cylinders
- John Deere heat-treated, chrome-plated cylinder rods with replaceable bushings
- Connect-under-pressure auxiliary couplers
- Quick-check hydraulic fluid-level sight glass
- 1,000-hour, 5-micron hydraulic filter
- ▲ High-flow hydraulics
- Axial-piston hydrostatic pump

Electrical

- Automatic engine/hydraulic shutdown protection system
- Auxiliary hydraulics operator-presence system
- Courtesy lighting
- Deluxe instrumentation EMU with: Operator-selectable monitoring – Hour meter, engine rpm, battery voltage, diagnostics, EMU configuration, engine coolant temperature, hydraulic oil temperature / LED

333G Electrical (continued)

- warning indicators – Glow plug, seat switch, seat belt, door open, auxiliary hydraulics, park brake engaged, 2-speed engaged, stop, low engine oil pressure, engine coolant over-temperature, battery not charging, air filter restriction, and hydraulic filter restriction
- ▲ Deluxe LED lighting package with additional cab-integrated side lights (2)
- Front and rear halogen work lights
- Triple-interlock operator-presence control system
- Backup alarm
- Battery, 925 CCA
- Horn
- ▲ Hazard warning lights
- ▲ Strobe light, amber

Operator's Station

- Deluxe cab headliner
- Electrohydraulic (EH) ISO-pattern joystick controls
- ▲ ISO-H switchable joystick controls and EH joystick performance package*
- ▲ 4-way switchable controls include EH foot control, ISO joystick control, H-pattern joystick control, and ISO and foot controls
- ▲ ISO controls with programmable detents and EH boom performance package;¹ also includes EH joystick performance package*
- Keyless-start sealed-switch module with integrated anti-theft system and operator memory preference settings
- Electronic push-button auxiliary controls
- Pull-down adjustable lap bar
- Quick-pivot ROPS
- Rear window
- Removable top window
- ▲ Sliding/locking/removable glass side windows
- ROPS/FOPS operator structure
- ▲ Glass cab enclosure
- Seat belt, 51 mm (2 in.), retractable
- ▲ Shoulder belt, 51 mm (2 in.) or 76 mm (3 in.)
- ▲ Severe-duty cab door and wiper system
- ▲ Water-shedding deluxe vinyl suspension seat
- ▲ Air-ride cloth, heated seat
- ▲ Air-ride vinyl seat
- 12-volt power port / Dome light / Cargo storage / Beverage holder

333G Operator's Station (continued)

- ▲ Air conditioning with heater/defroster
- ▲ AM/FM radio with auxiliary input and Bluetooth® for audio streaming
- ▲ Floor mat with left footrest
- Rearview mirror
- ▲ Rearview camera

Loader

- In-cab boom lockout to secure loader before exiting seat
- Patented John Deere Quik-Tatch™ (no grease required)
- ▲ Power Quik-Tatch
- Patented John Deere vertical-lift boom
- ▲ Hydraulic self-leveling on/off and ride control

Other

- ▲ SmartGrade™
- ▲ Slope Control
- ▲ Laser Slope Control
- ▲ Onboard grade indication: This option delivers onboard readout within LCD monitor that provides slope of blade (cross-slope direction) and mainfall (fore/aft direction) within ±0.5-percent accuracy
- Convenient front and rear tie-downs
- Environmental drains for all fluid reservoirs
- Chrome exhaust stack
- ▲ Engine oil/hydraulic fluid-sampling kit
- ▲ Forestry protection packages
- ▲ Heavy-duty rear grille
- ▲ Rear counterweights (available in sets of 1, 2, or 3), 78 kg (172 lb.) (each set)
- ▲ Single-point lift kit
- ▲ SMV sign kit
- ▲ Anti-vibration undercarriage system
- ▲ Track, 400-mm (15.8 in.) wide
- Track, 450-mm (17.7 in.) wide
- ▲ JDLink™ wireless communication system (available in specific countries; see your dealer for details)

⁸500-hour engine oil-change intervals when John Deere Plus-50 oil and John Deere oil filter are used.

*EH joystick performance package features switchable accelerator/decelerator, selectable propel speeds, creep control, boom- and bucket-speed settings, and 12-volt 3- and 14-pin attachment-control harness with dash-mounted 4th-function rocker switch.

¹EH boom performance package features include EH bucket self-level up and down, return to dig, return to carry, and boom-height kick-out.

While general information, pictures, and descriptions are provided, some illustrations and text may include product options and accessories NOT AVAILABLE in all regions, and in some countries products and accessories may require modifications or additions to ensure compliance with the local regulations of those countries.

Net engine power is with standard equipment including air cleaner, exhaust system, alternator, and cooling fan, at standard conditions per SAE J1349 and DIN 6270B, using No. 2-D fuel at 35 API gravity. Gross power is without cooling fan. Specifications and design subject to change without notice.

Wherever applicable, specifications are in accordance with SAE standards. Except where otherwise noted, these specifications are based on a unit with standard equipment, full fuel tank, and 79-kg (175-lb.) operator.



DKAGCTL333 (22-10)



JOHN DEERE